



Co-extension and near-synonymy in color categorization

Alena Anishchanka

Dirk Geeraerts

Dirk Speelman



RU Quantitative Lexicology and Variational Linguistics

Outline

- Theoretical background
- Synonymy in the color domain
- Why co-extension?

- Data and methodology
- Out of the Blue
- Lectal variation in coextensive color categories

- Further steps

Synonymy in the color domain

Aim: to explore the patterns in the referential overlap between color categories that are traditionally seen as synonymous

Three perspectives

- Lexicographic
- Corpus (usage) based
- Experimental

Lexicographic perspective

	WEB	OED	LONG	OALD	CIDE	CCELD
Crimson	deep purplish red	deep red	deep purplish red	deep red	strong, slightly purplish, deep red colour	dark, purplish red colour
Magenta	deep purplish red	-	bright pink colour	a colour between purple and red	dark purplish red	dark, reddish purple
Maroon	dark red	brownish-crimson or claret colour	very dark red-brown	dark brownish red	dark reddish purple	dark reddish purple
Plum	dark reddish purple	A shade of purple	dark red	dark reddish purple	darkish purplish red	dark-red or purple
Puce	-	purple-brown or brownish purple	dark brownish purple	brownish purple	dark purplish red	dark purple

Lexicographic perspective

	WEB	OED	LONG	OALD	CIDE	CCELD
Navy	A dark blue	A dark blue	Very dark blue	Dark blue	Dark blue	Very dark blue
Indigo	dark grayish blue.	deep violet-blue	dark purplish blue	deep blue	bluish purple	A dark colour between blue and violet
Cobalt	a strong greenish blue	deep blue	bright blue-green	deep blue-green	deep blue or greenish-blue	-
Sapphire	deep purplish-blue	pure bright blue	bright blue	bright blue	bright blue	deep blue
Ultramarine	vivid blue	special deep-blue	very bright blue	very bright blue	bright blue	very bright blue

Corpus (usage-based) perspective

- Steinvall (2002)

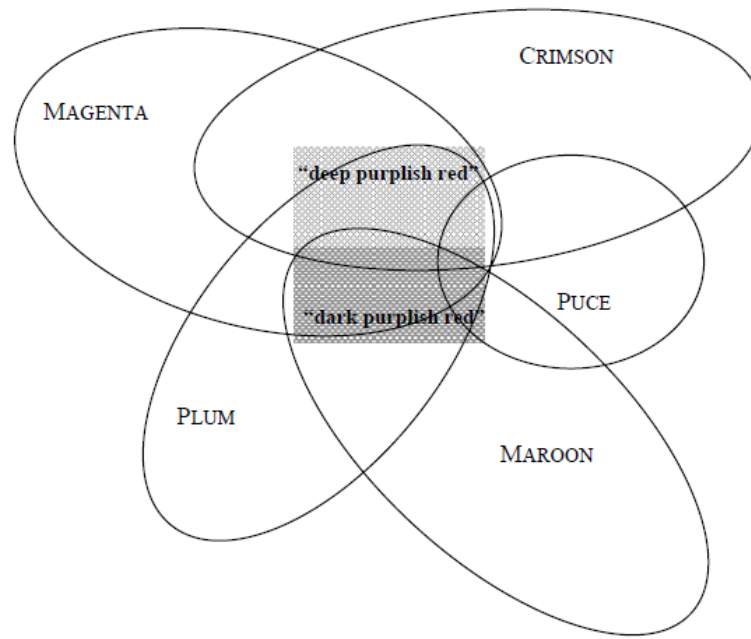

Experimental perspective

- Berlin & Kay (1969)
- MacLaury (1997)

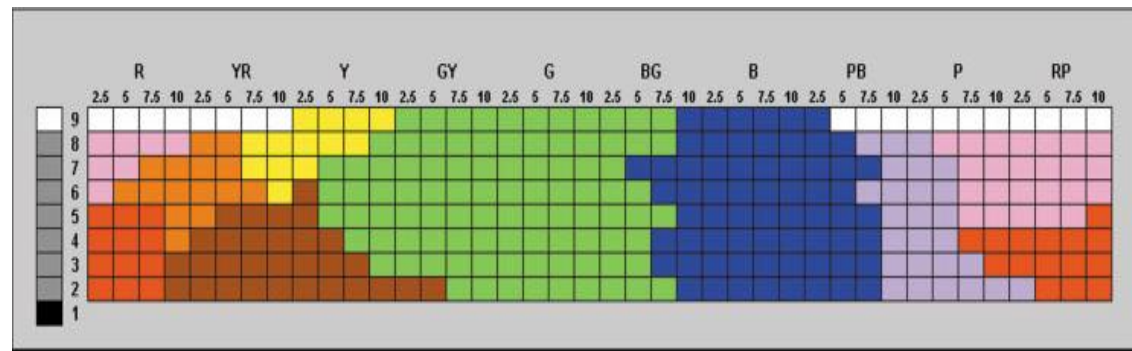
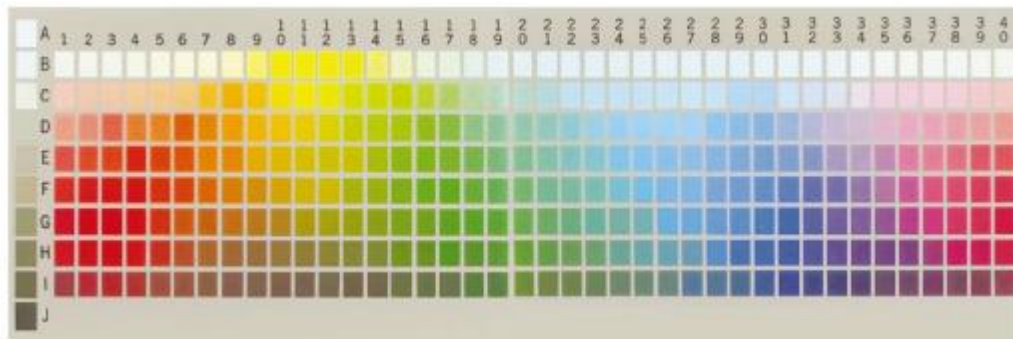

Why co-extension?

MacLaury 1997

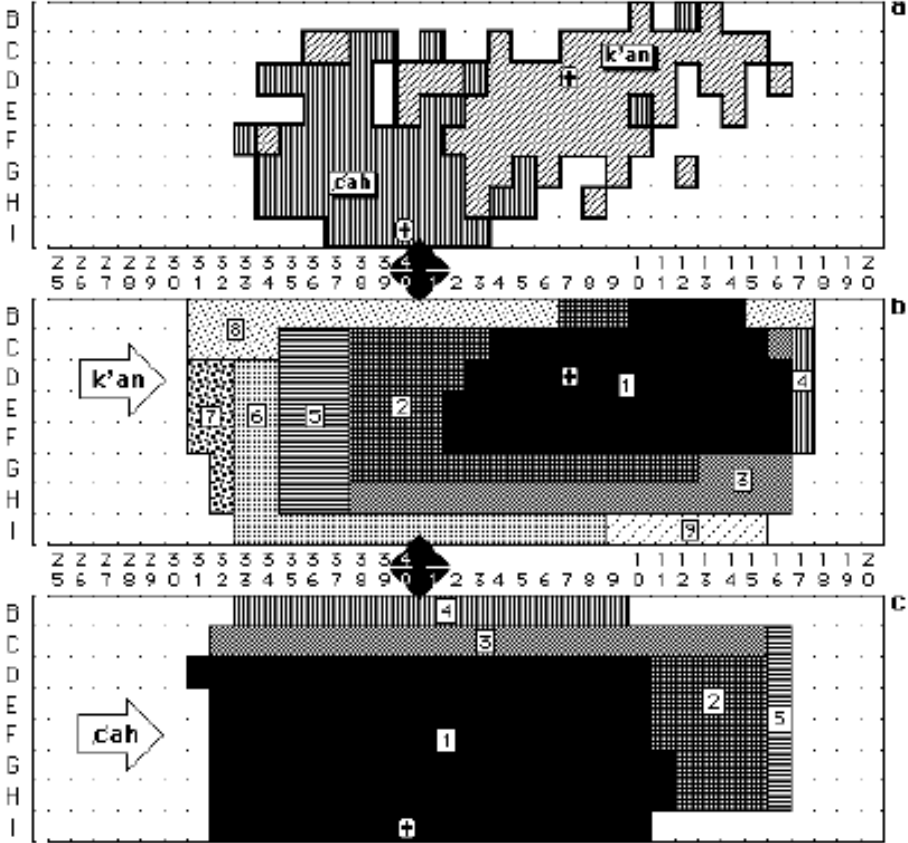

Data

product domains:

- cars: 45232 (*GM Group, Chrysler Group, Ford , Toyota, Volkswagen etc.*)
- clothing: 17116 (*J.Crew, Banana republic, Land's end, Covington (Sears), Attention (Kmart), Columbia, Adidas, Authentic Pigment, etc.*)
- make up: 4167 (*Estee Lauder, Trish McEvoy, Bobby Brown, Elizabeth Ardenn, MAC, Avon, Maybelline etc.)*)
- house paints: 4104 (*Benjamin Moore, Dunn-Edwards, Glidden, etc.*)
- total ca. 63000



Data

MAYBELLINE®
NEW YORK

Log In My Beauty Profile Search: GO

WHAT'S NEW PRODUCTS MY COLOR ADVISOR MUST-HAVE LOOKS BACKSTAGE AT MAYBELLINE VIDEO GALLERY

Face Eyes Lips Nails Tools | Beauty Awards Replace an Old Fave Online Retailers Signature Lines

Explore Lips: Lipcolor Lip Gloss Lip Liner Moisture Extreme Lipcolor

LIPCOLOR

Moisture Extreme® Lipcolor

Christy is wearing Moisture Extreme Lipcolor in Candied Apple.



Click on swatch: Metallic Mauve AZ2

EMAIL PRINT

Pinks								
Mauves								
Plums								
Corals								
Reds								
Browns								
Naturals								

Why You'll Love It

Active power of a lip balm provides deep moisturization for voluptuous lips drenched in color.

- 56 sumptuous shades across every shade family to complement all skin tones
- Non-feathering and non-bleeding
- SPF 15 protection
- ▶ [View all Moisture Extreme products](#)

For Best Results

Apply your lipstick by starting in the center of your upper lip. Work from the center to the outer edges of your lip, following the contours of your mouth. Repeat the technique on your lower lip.



MYCOLOR ADVISOR

YOUR PERSONAL SHADE & PRODUCT GUIDE

INSTANT COLOR GRATIFICATION

Like this product? We can point out what shades would look best on you. Just answer these two questions.

What's your skin tone?

L Light
 M Medium
 D Dark

▶ Need help choosing a skin tone?

What color are your eyes?

Blue
 Green
 Hazel
 Brown

Got another makeup wish? Tell us.
 Have a product type in mind?

MORE TO KNOW

▶ Lipcolor 101
Kiss-and-tell lipcolor.



Step 1 Primary macrocategories

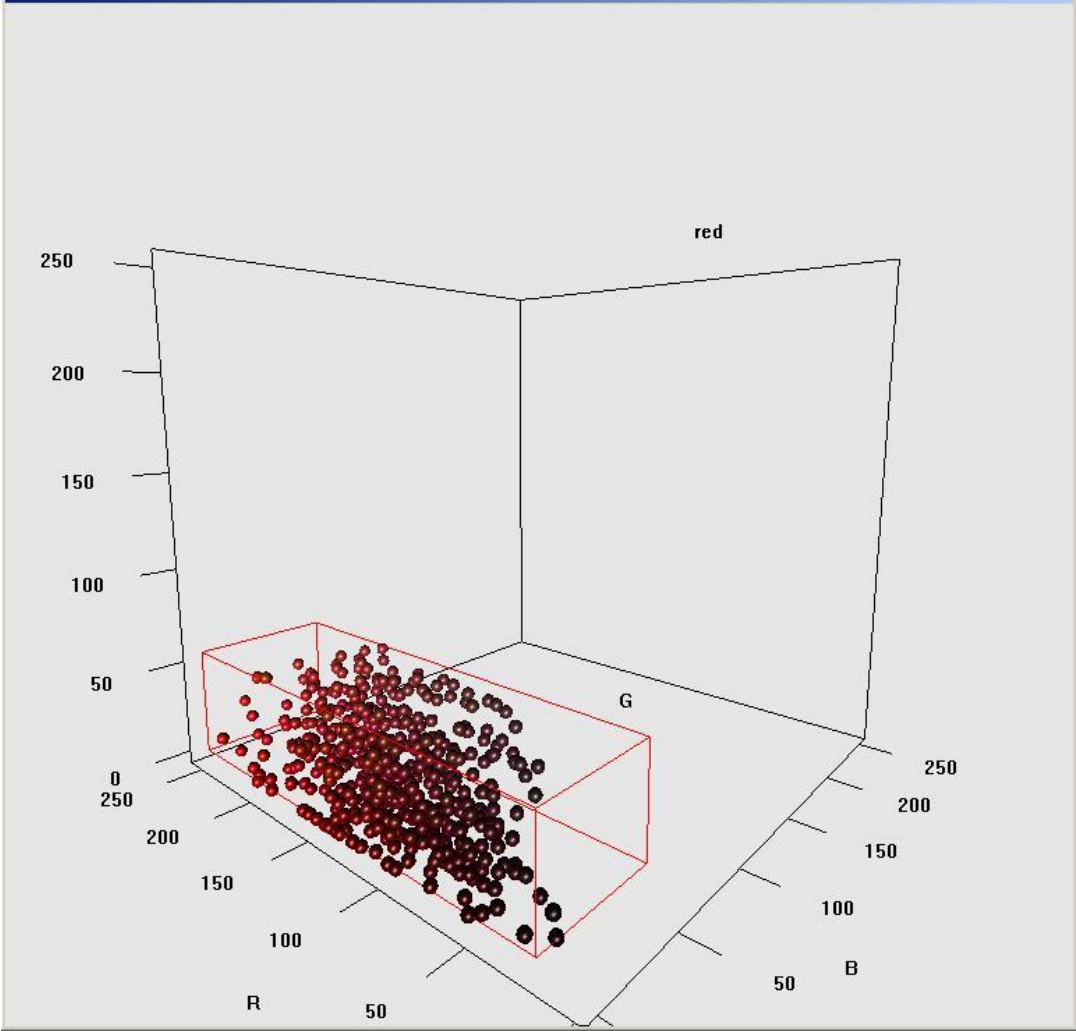

Step 1 Primary macrocategories

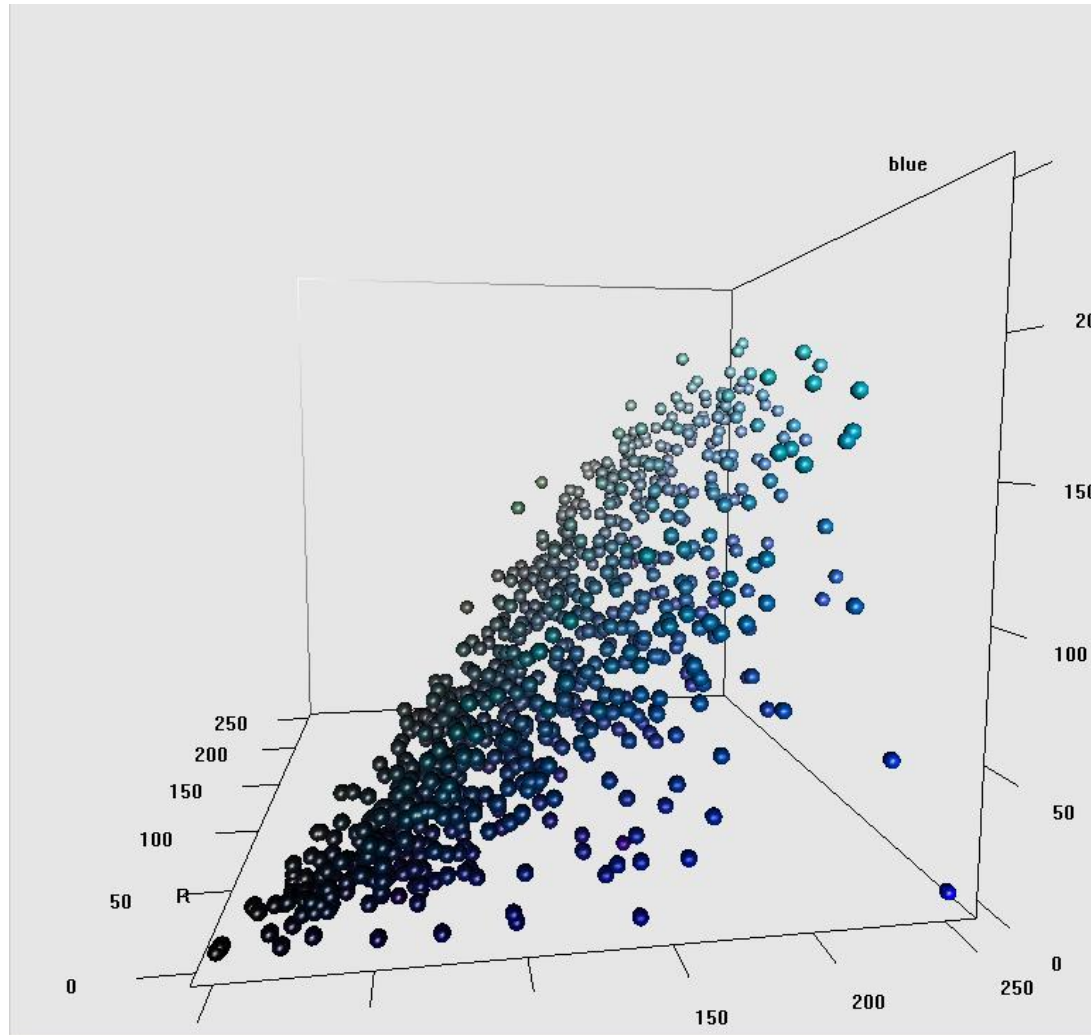

Step 1 Primary macrocategories (observations + volumes)

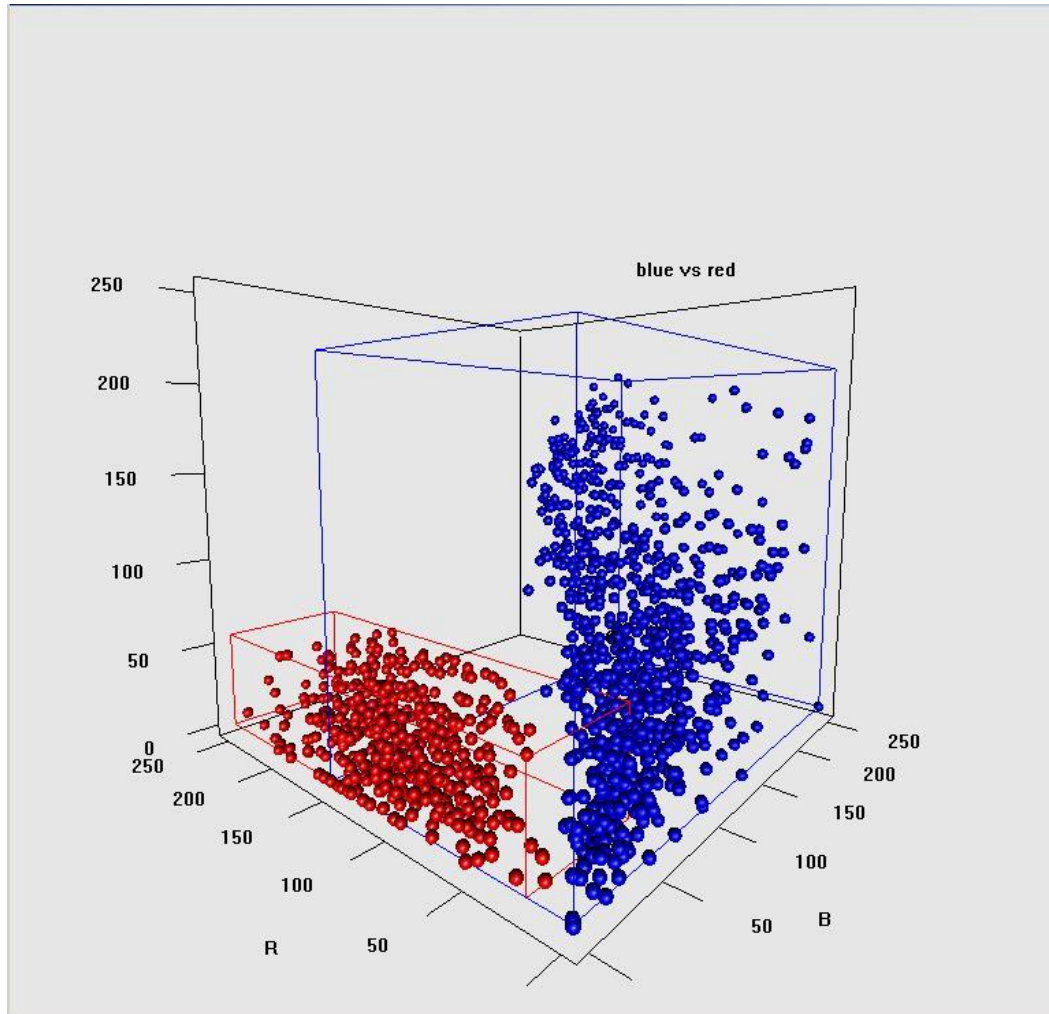

Step 2 Secondary macrocategories

Navy

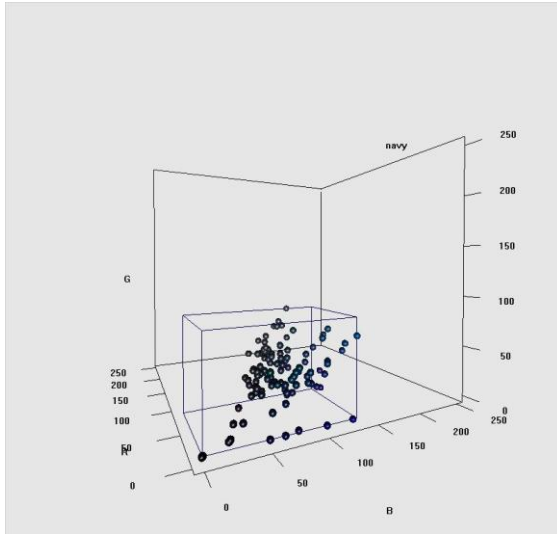

Indigo

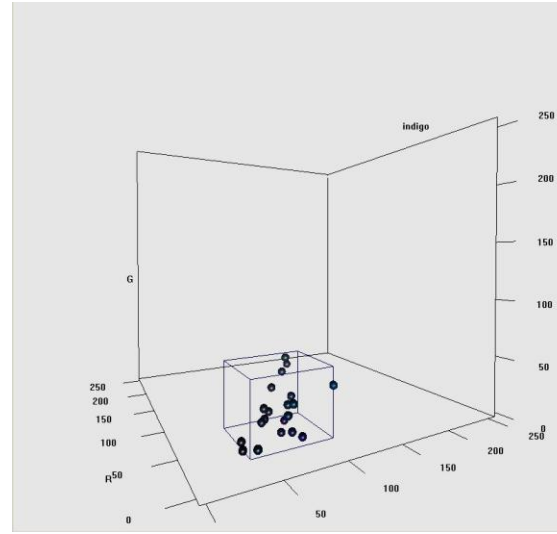

Sapphire

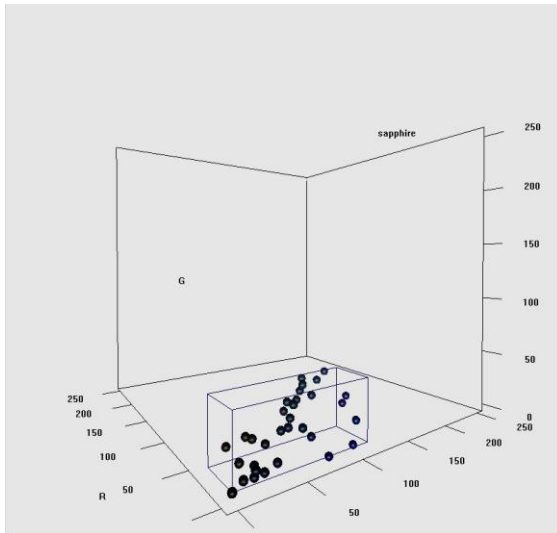

Cobalt

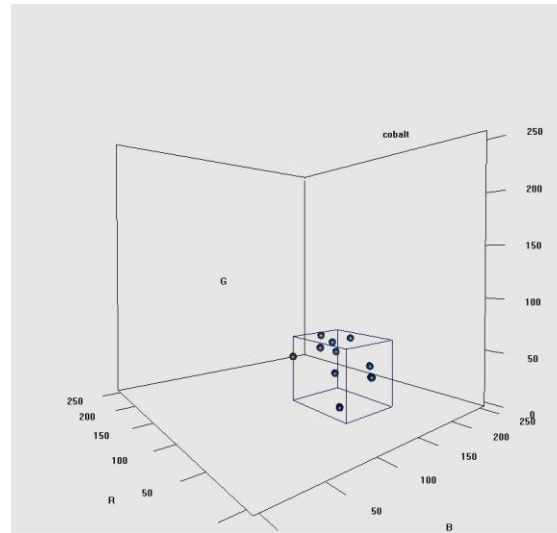

Step 3 Category overlap (volumes)

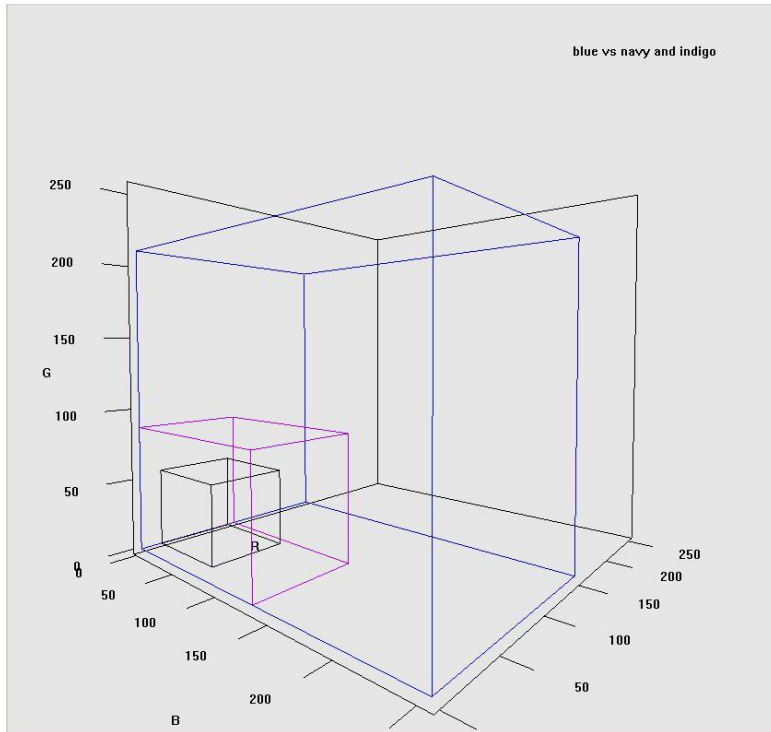

Navy (purple box)
Indigo (black box)

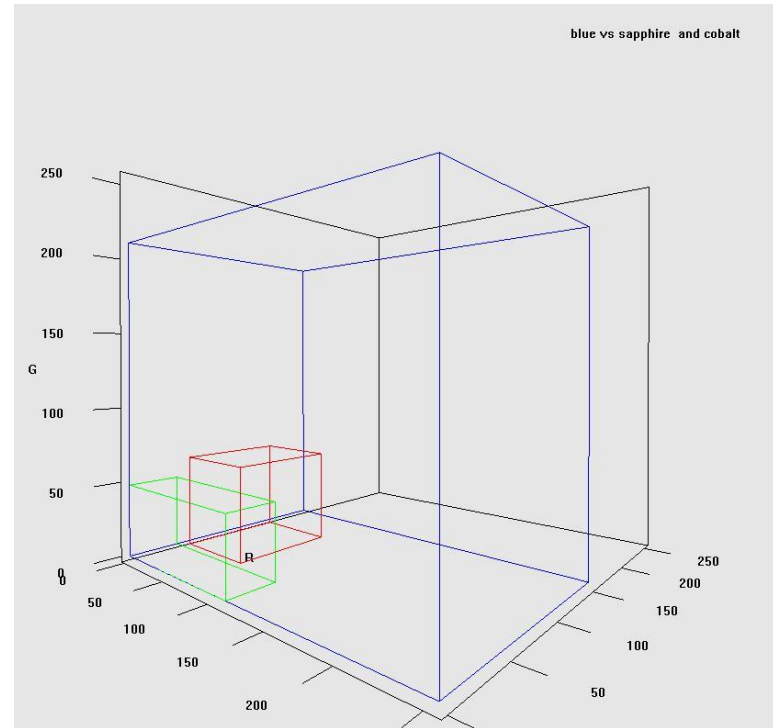

Sapphire (green box)
Cobalt (red box)

Step 3 Category overlap (volumes)

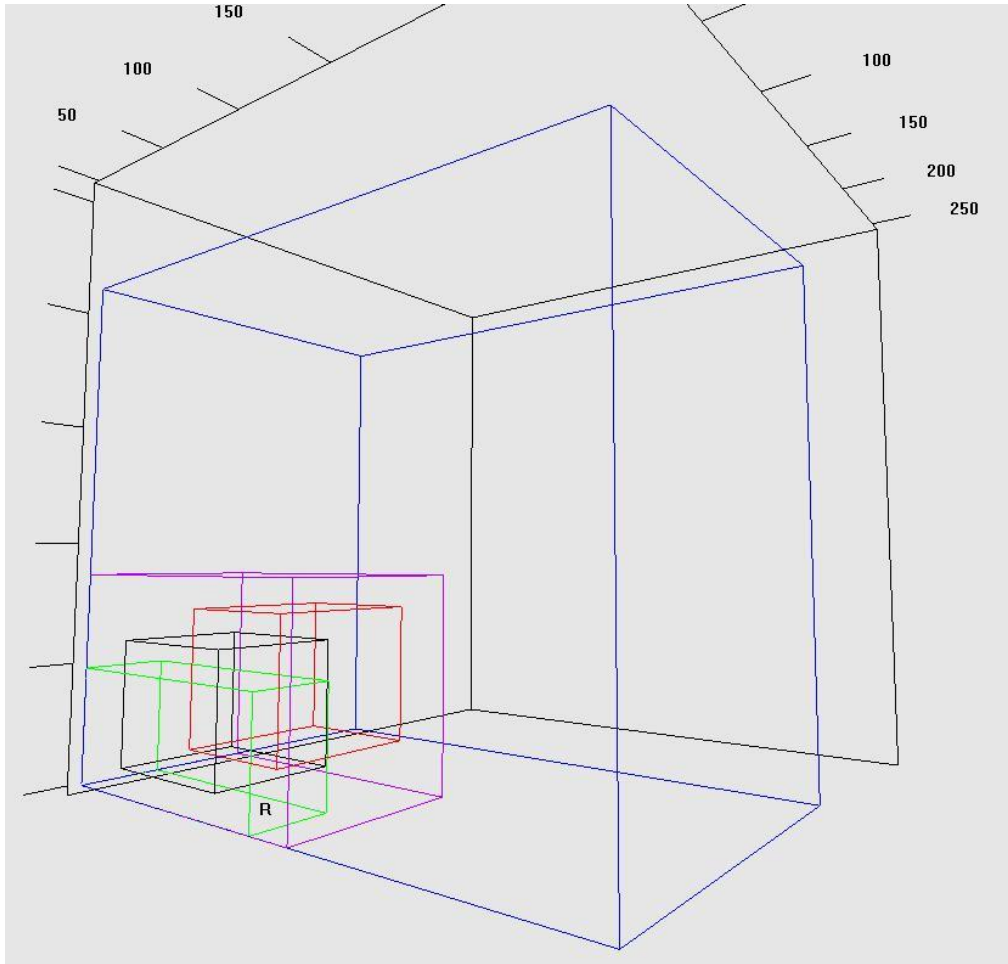

Navy (purple box)
Indigo (black box)
Sapphire (green box)
Cobalt (red box)

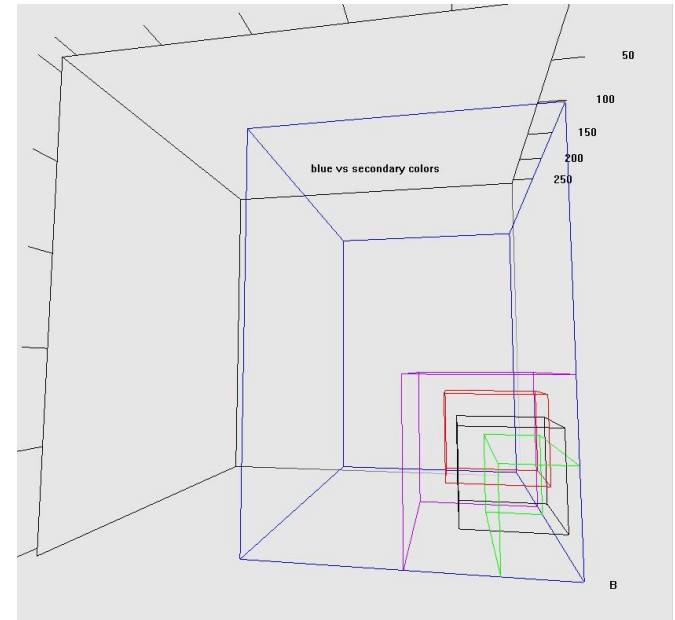

Lectal variation in the category size

Blue

- Cars (black box)
- Clothes (green box)
- Makeup (red box)
- Paints (purple box)

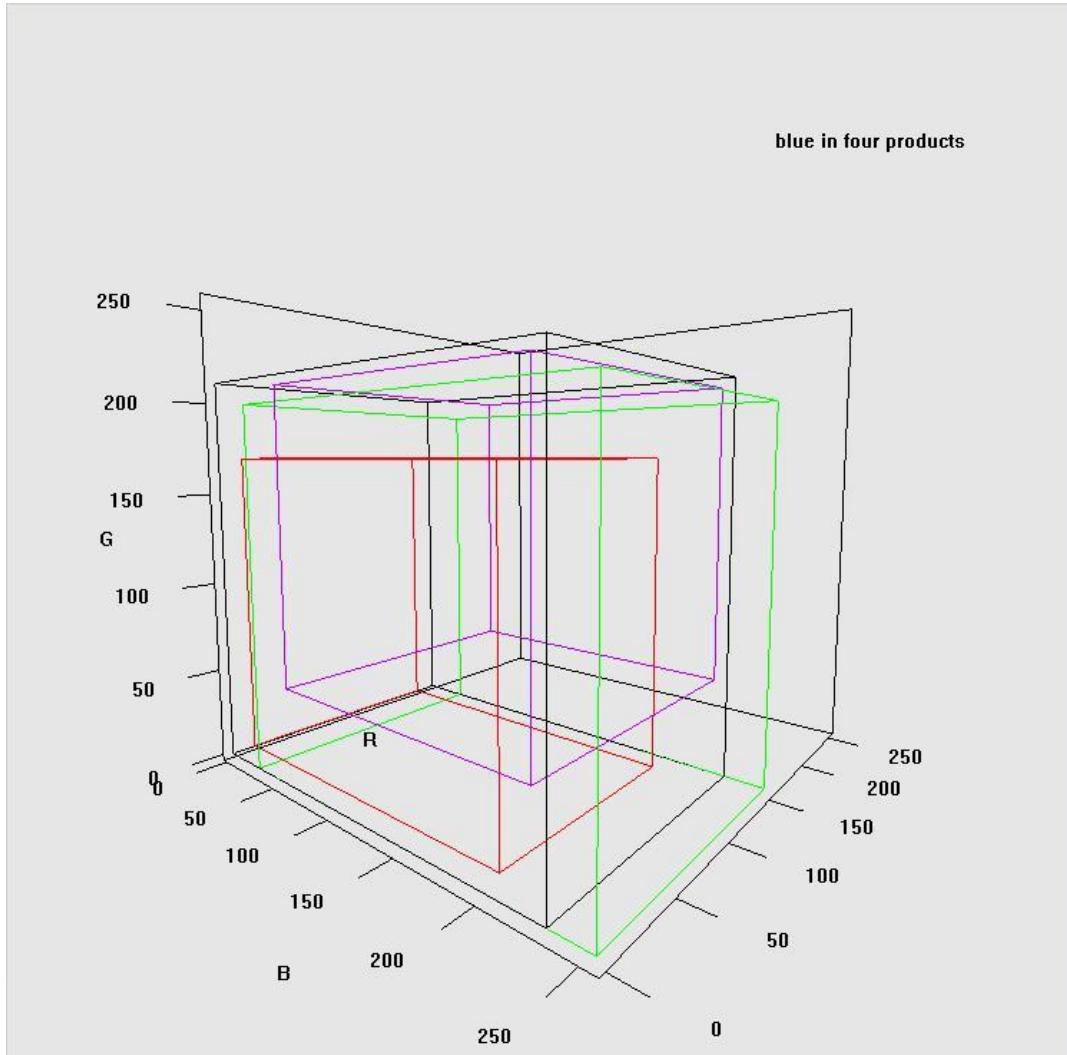

Lectal variation in the category size

Cars (black box)
Clothes (green box)
Makeup (red box)
Paints (purple box)

Navy

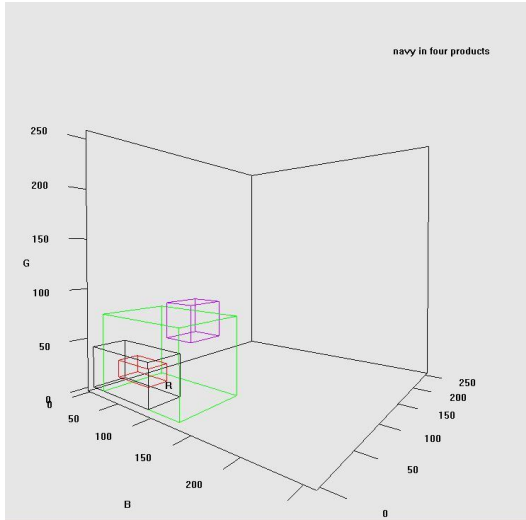

Sapphire

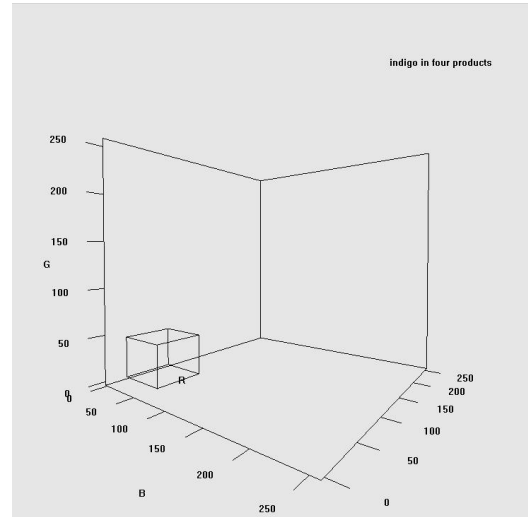
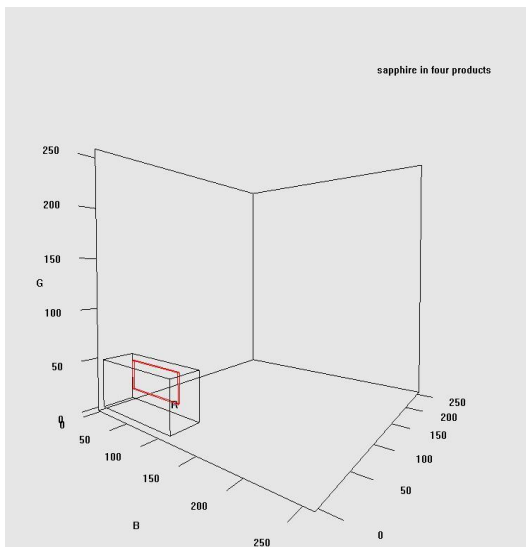

Indigo

Cobalt

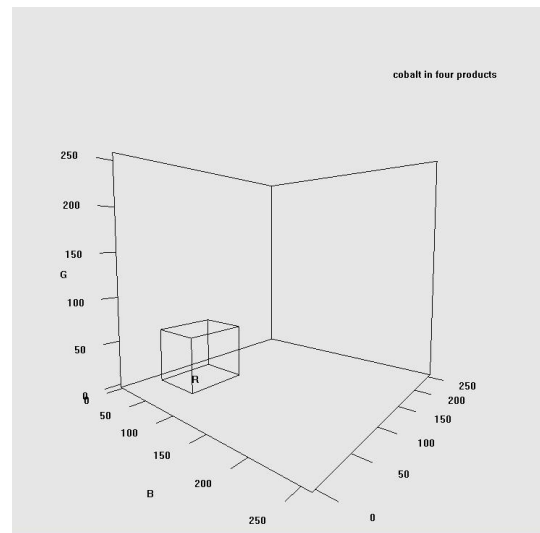

Lectal variation in the category size

Cars (black box)
Clothes (green box)
Makeup (red box)
Paints (purple box)

Navy

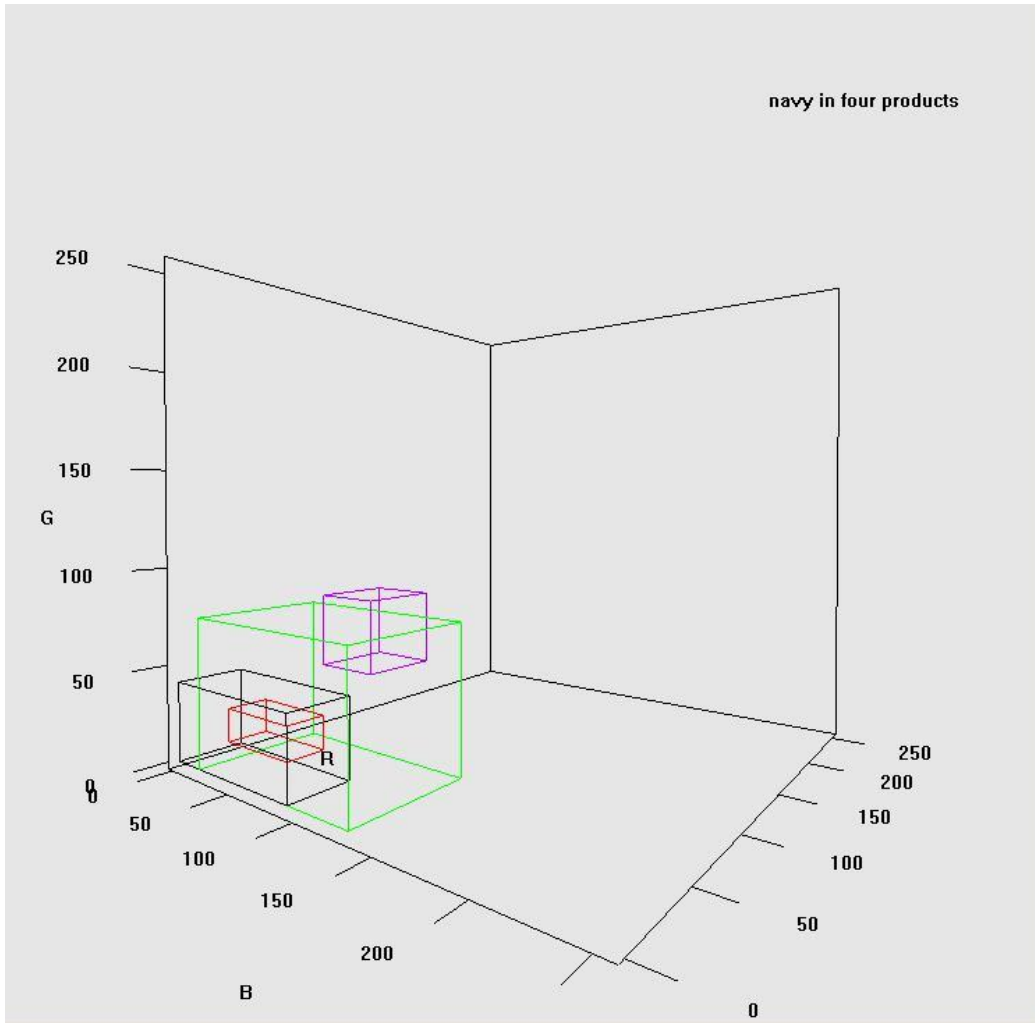

Lectal variation in the category overlap

Navy (purple box)
Indigo (black box)
Sapphire (green box)
Cobalt (red box)

Cars

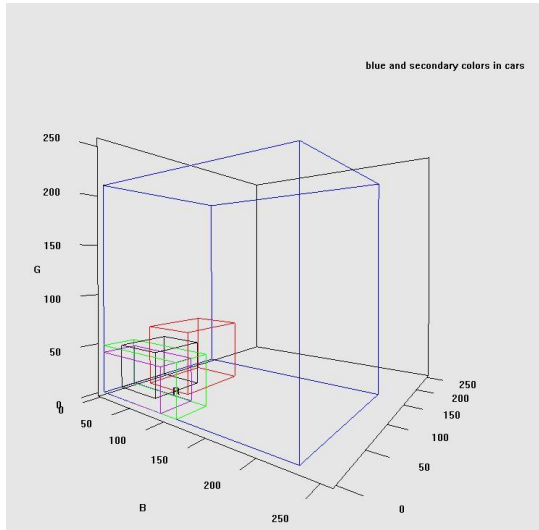

Clothes

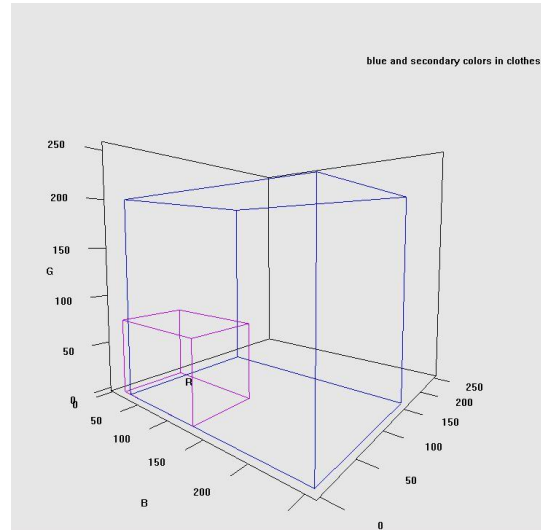

Makeup

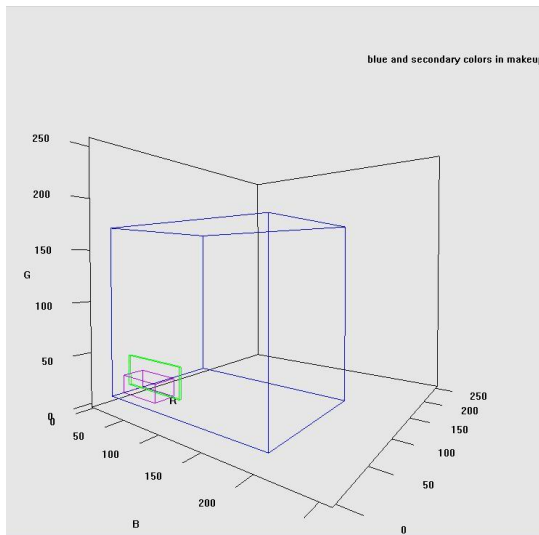

Paints

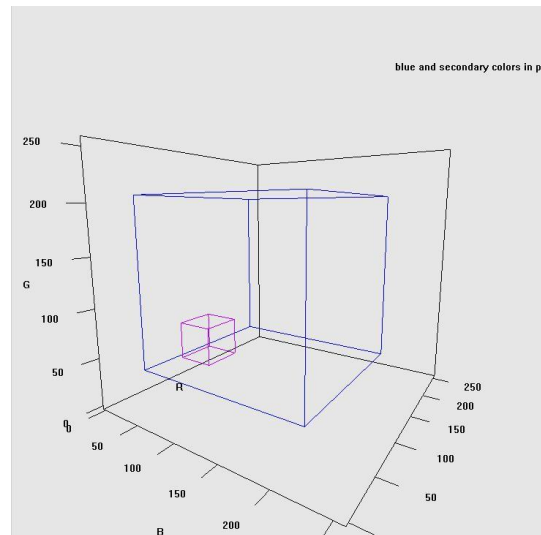

Further steps

- category structure (more and less prototypical category members)
- quantification of the overlap patterns
- criteria for identifying candidates for secondary color categories
- ten more primary categories to go

References

- Berlin, B. and P. Kay, 1969. *Basic color terms: Their universality and evolution*. Berkeley, CA: University of California Press.
- Geeraerts, D., Grondelaers, S. and P. Bakema, 1994. *The Structure of Lexical Variation. Meaning, Naming, and Context*. Berlin: Mouton de Gruyter.
- MacLaury, R.E., 1997. *Color and Cognition in Mesoamerica: Constructing Categories as Vantages*. University of Texas Press, Austin.
- Steinvall, A., 2002. *English Color Terms in Context*. Ph.D. Dissertation. Umeå University: Skrifter från moderna språk 3.

for further information:
Alena.Anishchanka@arts.kuleuven.be

